

## PROF MISNI SELECTED AS RECIPIENT OF PPRN FUND

Written by: **Dr Ahmad Ibrahim**  
UM Adjung Professor

Despite many earlier attempts by the government to get business to invest more in R&D, the success rate remains low. This would not augur well as the nation's economy migrates from a low value assembly operation into one that increasingly deploys innovation as a way to add value and improve productivity. Recently, the government through the Ministry of Education, introduced another initiative to invigorate more active collaboration between academia and business. The Public Private Research Network, PPRN, is another attempt to get business to tap on the expertise available within local universities to exploit research and innovation as an instrument of productivity improvement.

Prof Dr. Misni Misran of University Malaya's Department of Chemistry, Faculty of Science, has been selected as a recipient

of a Demand Driven Innovation For Public & Private Research Network Fund. The objective of PPRN projects is to help industries solve problems that they present to the program in order to enhance their productivity. Prof. Dr. Misni will collaborate with MGV Industries Sdn. Bhd. for a project entitled "Stability of Suspended Nutrients for MGV Industries Sdn. Bhd".

MGV Industries Sdn Bhd manufactures and distributes bottled beverages. Their products consist of soft drinks, isotonic energy drinks and clarified sparkling fruit juices. The factory uses the latest enzymatic treatment and micro filtration technology in their production. They distribute their products through various sales channels which include major hypermarkets like Giant, Mydin, Tesco and Carrefour. In addition, the company also exports to Singapore, Brunei, Indonesia, Myanmar, Cambodia, Maldives, Dubai and China.

Prof Misni is also one of the nation's foremost experts on the subject of colloids. This is where Prof Misni is the right candidate to help MGV Industries tackle some of its product development research.

Professor Misni's has interesting views about the nation's strategy on science. On nanotechnology, he lamented about the lack of directions and focus. On the strategy to participate in the growing Graphene technology business, he cautioned that we should tread carefully. We should be wary of the fact that even the Carbon Nanotube CNT which was at one time hailed as offering lucrative business opportunities has now become just another

commodity. But most of all whatever research we invest in, we need to evaluate the true business potential from the start. He cited a case of the earlier project which succeeded in technically producing a promising nano-material from rice husks only to find out that it is not commercially viable because of the supply problems with rice husks! Researchers like Prof Misni should continue to be tapped not only for their scientific expertise but also for their strategic thinking in relation to the country's innovation agenda.



Prof Dr. Misni Misran

### Contact

Prof Dr. Misni Misran  
C217, Colloid lab,  
Department of Chemistry, Faculty of Science,  
University of Malaya 50603 Kuala Lumpur  
Tel: +603-79676776 • Fax: +603-79674193

Despite the growing concern over the declining interest in science among the nation's young, there are exceptions. Ms Kavita S Subramaniam who hails from Tampin Melaka is one such exception. The fact that both her parents are teachers may have contributed to her good grounding in science. She showed her potential even during her primary school days when she jumped class from standard three to five. Her first degree was earned at the Multimedia University, MMU. And that was in bioinformatics. That did not stop her from pursuing a Masters Degree in medical research at the University Malaya's Department of Pharmacology in the Faculty of Medicine. This was later converted into a PhD program. Her thesis titled "Secretion from cancer associated fibroblasts in endometrial cancer progression" is in the final stage of writing up. It would be good for the nation if we can have more among the young like Kavita to drive the country's science and innovation agenda.

Her excellent research must have attracted the attention of the Judges of the 2015 Novartis Next Generation Scientist (NGS) program. The NGS program is an intensive 3 month-long internships at the research site in Basel, Switzerland. The program allows interns to spend the summer (June to September) working on a jointly-agreed upon, pre-competitive scientific or clinical research project internship. Ms Kavita is the first Malaysian to be selected for this program. This speaks well for the research ecosystem at UM.

In the world today cancer remains among the major killer diseases. There is active research

## KAVITA WINS COVETED INTERNSHIP WITH NOVARTIS

Written by: **Dr Ahmad Ibrahim**  
UM Adjung Professor

worldwide looking for effective therapy for the many different types of cancer. Ms Kavita and her PhD supervisor, Associate Professor Dr Ivy Chung are interested to understand how the microenvironment surrounding cancer cells can be explored in designing better therapy for cancer patients. They are particularly interested in a special type of fibroblast cells, known as cancer-associated fibroblasts. Their hypothesis is that molecules secreted by cancer-associated fibroblasts may be responsible for the progression of endometrial cancer. Their study showed that fibroblasts from different environments (non-cancerous versus cancerous) display characteristics that will affect tumor behaviour differently. Part of their study has been published in PLoS One (Subramaniam KS et al. (2013) 8(7):e68923). There is hope that their research may lead to better identification of target drugs which will stop the secretion.

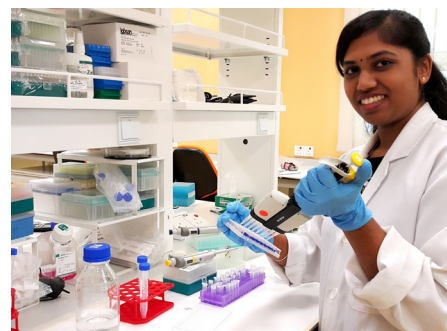

Ms Kavitha doing research in lab.

The three month stint with NGS program will hopefully provide the opportunity to learn how to translate her laboratory's findings to become useful treatment strategies. It is also an opportunity to gain invaluable perspective from the pharmaceutical industry about drug discovery and validations before ending in the market place.

With her expressed plan to continue in a research career after her PhD, this would augur well as the nation strives to attract and retain more talent in scientific research, especially in the medical field.

### Contact

Kavita S. Subramaniam  
Translational Core Laboratory  
Faculty of Medicine, University Malaya  
Phone : 03-79496385

## UNIVERSITY OF MALAYA (UM) ECO-GREENENERGY™ HYBRID WIND-SOLAR OUTDOOR LIGHTING SYSTEM INSTALLED AT BICYCLE TRACK OF KUALA LUMPUR CITY HALL (DBKL)

Written by: **Assoc. Prof. Dr. Chong Wen Tong**

Promotion of green technology presents the most viable way of meeting the growing energy demand under the environmental constraints. The Malaysian government has a strong role to play in green technology by way of introducing necessary policies and implementing them. As researchers continue searching for the suitable local green technology, Assoc. Prof. Dr. Chong Wen Tong and his fellow team members from Department of Mechanical Engineering, University of Malaya (UM) have come up with an innovative Eco-Greenergy™ Hybrid Wind-Solar Outdoor Lighting System, which is not only an energy efficient system, but can also be seen as the epitome of modern day green technology.

The Eco-Greenergy™ Hybrid Lighting System is a compact system that harmoniously integrates a vertical-axis-wind-turbine with the novel omni-direction-guide-vane (ODGV), solar panel, and LED lighting. The ODGV consists of several guide-vanes that are evenly arrayed around the VAWT to increase the on-coming wind speed and also acts as a protective barrier for the wind turbine in case of blade failures. The acrylic guide-vanes also serve as unique decorative light-plates during night time.

With tremendous amount of hard work, patience, and belief, Dr. Chong was first awarded a Pre-Commercialized Prototype Fund to develop and install the product at suitable locations within the campus in 2014. It was funded by UM via UM Center of Innovation and Commercialization (UMCIC). Dr. Chong and his team came up with the first prototype of the hybrid outdoor lighting system, located next to the outdoor gymnasium, opposite the 1st Residential



College University of Malaya. After 2 months, they managed to install another unit in front of the UM Research Management & Innovation Complex, followed by 3 more units at UM Ulu Gombak Facilities. With the impressive progress and performance of this project, Dr. Chong was invited to present this innovative system to the Ministry of Federal Territories at Putrajaya during the Mesyuarat Jawatankuasa Penyelarasan,

Pembangunan, dan Pelaksanaan Teknologi Hijau Wilayah Persekutuan Bil. 2/2014 in October 2014. After several meetings and evaluations of this system, 2 locations had been proposed along the new 5.5km DBKL Bicycle Track from Mid Valley to Dataran Merdeka as the trial site for the UM Eco-Greenergy™ Hybrid Wind-Solar Outdoor Lighting System. Despite the tight schedule, Dr. Chong's team, industrial partners and the DBKL officers managed to fabricate and successfully install the hybrid lamp post at the starting point of the bicycle track before the launching by the Mayor of Kuala Lumpur, Datuk Seri Hj. Ahmad Phesal Hj. Talib on 14<sup>th</sup> April 2015.

In brief, the design of this hybrid green system addresses the recycling, sustainable manufacturing, reduction of material and energy consumption and transportation issues. It serves as an instrument to bring about the awareness of green technology to the public, and also more importantly, provide a safe path for our local cyclist. Enclosure: photos

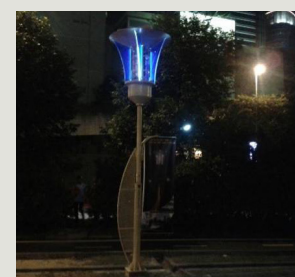
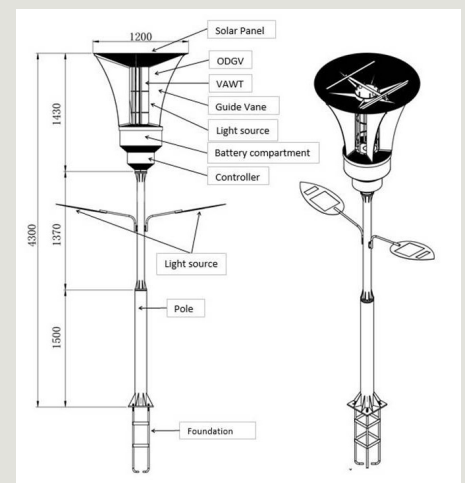

The lamp post installed at the DBKL Bicycle Track (near Mid Valley)

### Contact

Assoc. Prof. Dr. Chong Wen Tong  
Dept. of Mechanical Engineering  
Faculty of Engineering, University of Malaya,  
50603 Kuala Lumpur  
chong\_wentong@um.edu.my  
Tel: +6012-7235038 • Fax: +603-79675317